

HIGH-POWER
Pneumatic
Series

High-Power Pneumatic Series for *BT30 Machining Centers*

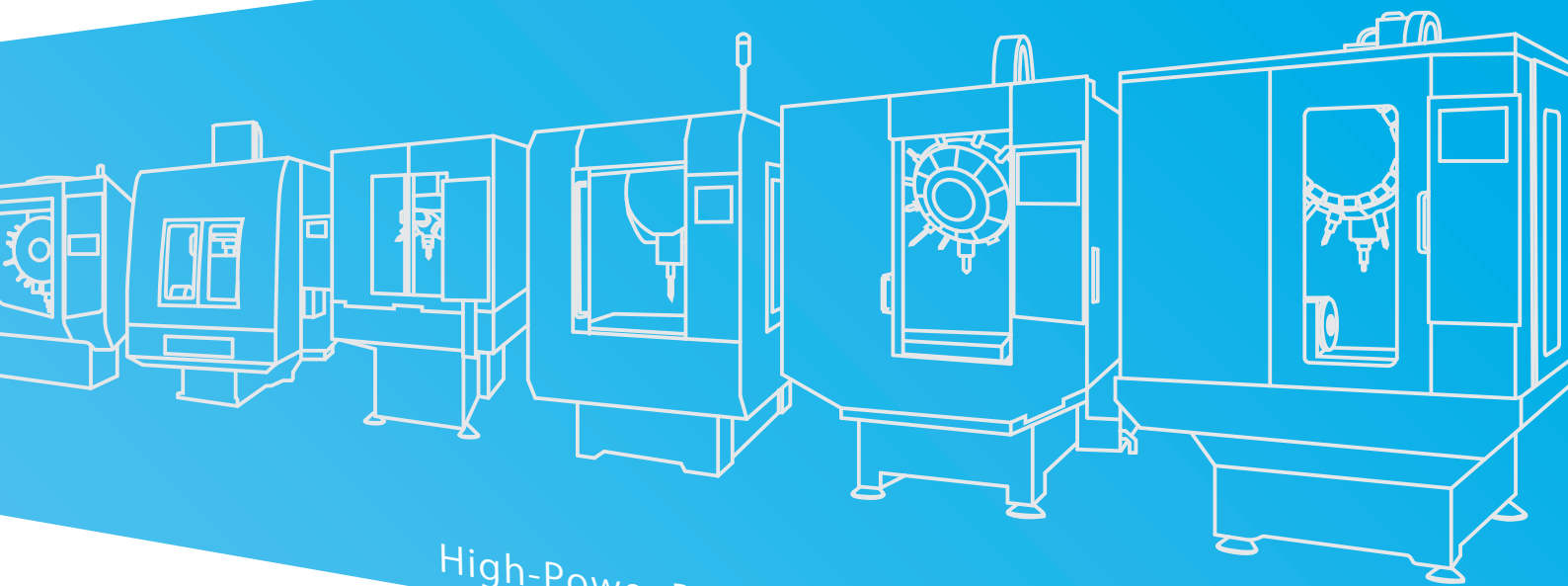

High-Power Pneumatic Series for BT30 Machining Centers

KOSMEK
Harmony in Innovation

High-Power Pneumatic Series

4000 units of pneumatic fixture

2011.11 ~ 2013.10

Higher Clamping Force with

High-Power Pneumatic Clamp with Mechanical Locking System PAT. P

※ The drawing shows the swing clamp.

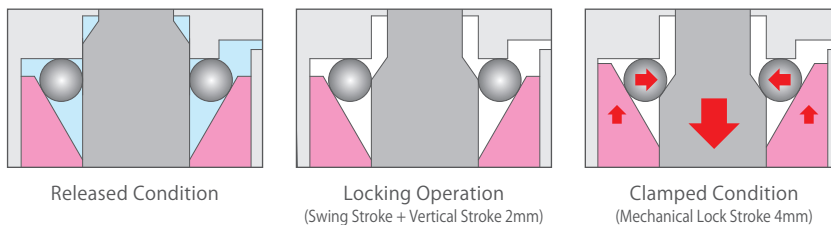
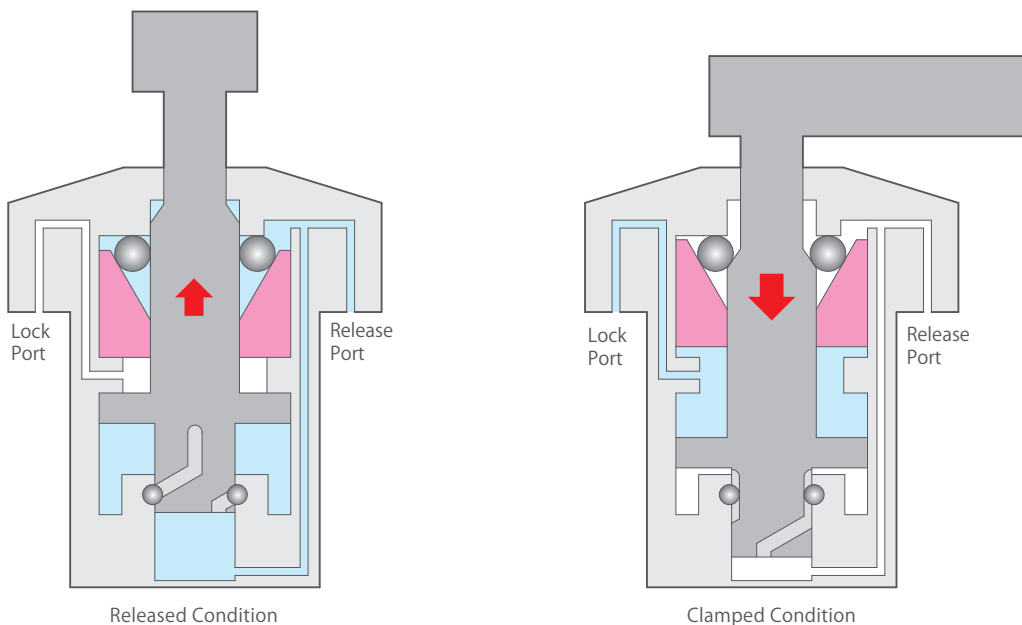



Model WHE



Model WCE

systems have been sold!!

Built-In Mechanical Lock (Wedge Mechanism)

Main Features of High-Power Pneumatic Clamp

Reference comparison of cylinders with piston diameter $\phi 40$ (Air Pressure 0.4MPa, Lever Length 60mm)

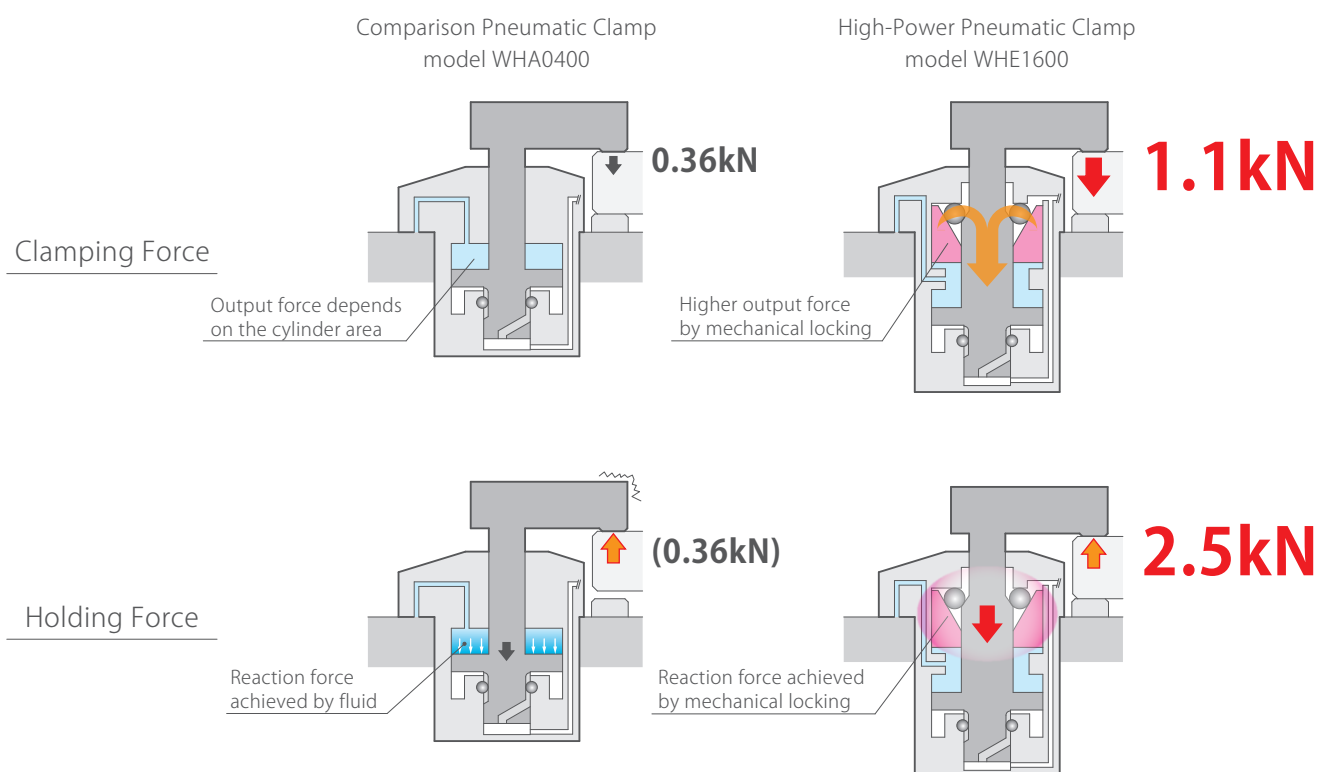

Advantages of High-Power

(**Hydraulic Clamp** → **High-Power Pneumatic Clamp**)

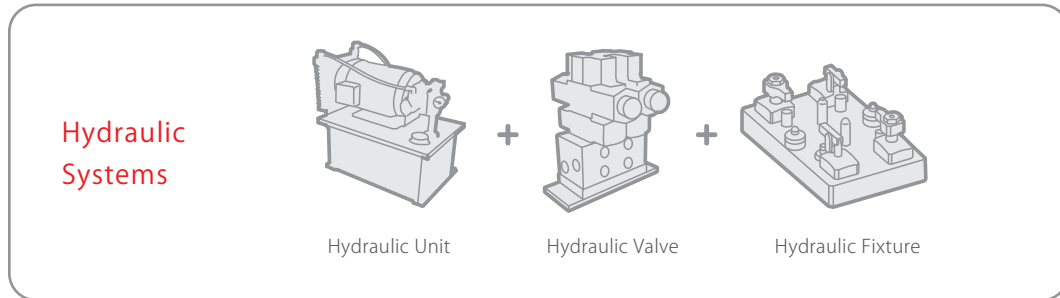

Energy-Saving

High-power pneumatic system requires only air resulting in cost reduction.
No hydraulic unit required. Reduction of electric power consumption/CO2.

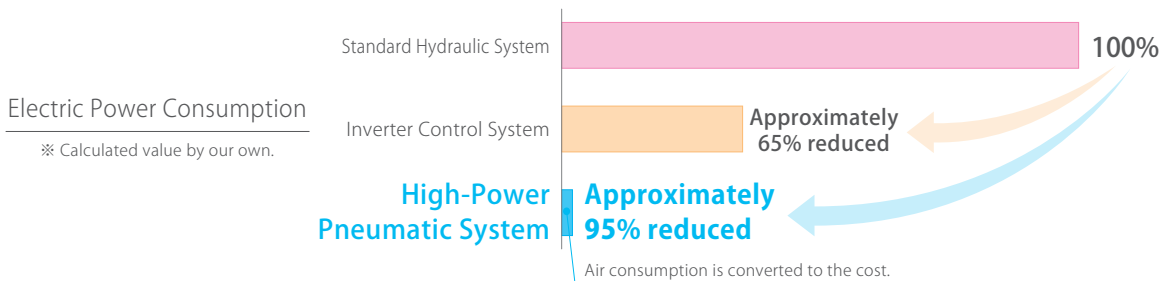

Cost-Reduction

The initial cost of high-power pneumatic system is much less than that of hydraulic system.
The running cost is also reduced with less maintenance.

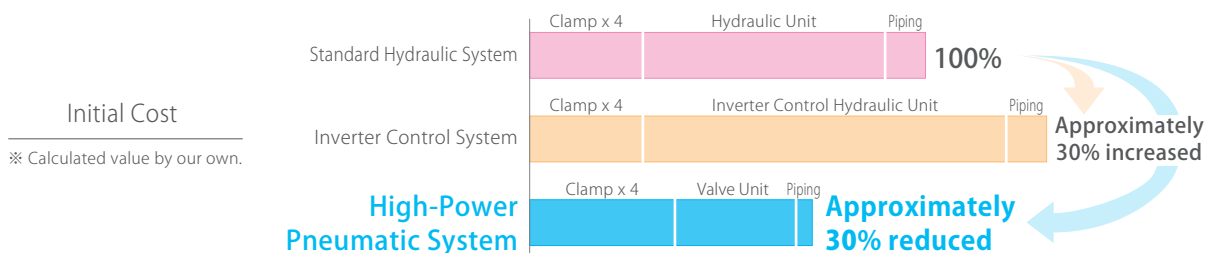

Pneumatic Systems



Model WHE



Model WCE

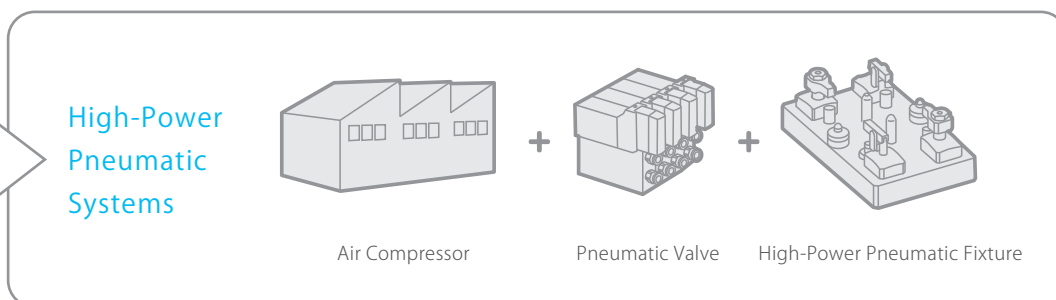

Less Workload

Installation is easily done with air piping, since there is no need of hydraulic piping. It is the solution to problems such as fluid leakage and temperature effects.

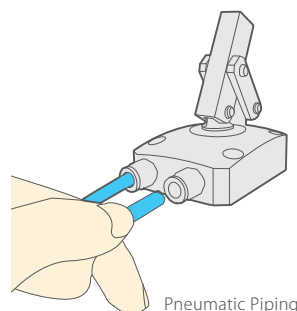
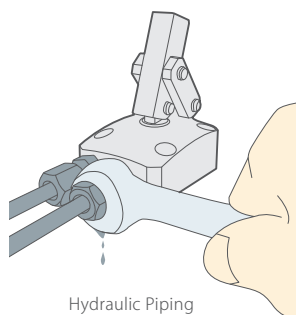

High Power

Holding force with mechanical locking (wedge) function withstands the reaction force similar to hydraulic clamps. Also, it enables high speed machining on both front and back faces.

【 Machining Condition 】			
Drill Diameter	8.5 mm	Cutting Speed	25 m/min
Main Axis Revolution	936 rpm	Feed Speed	0.100mm/rev
Workpiece Material	S45C	Clamping Force	860N (430N×2)

Displacement Amount

※ Results of machining by our own.

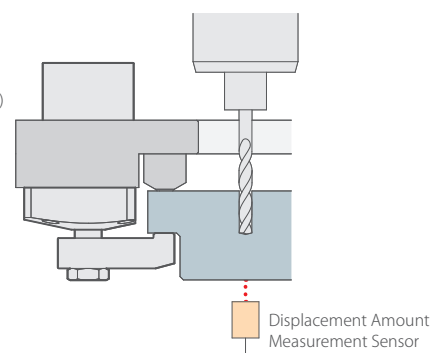
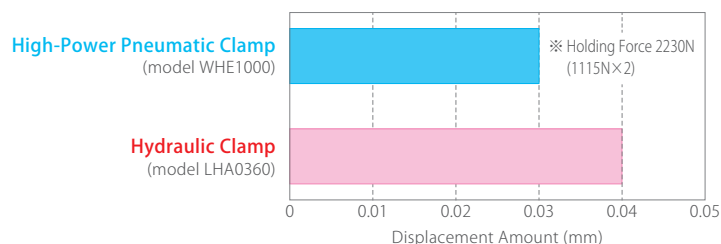

Advantages of High-Power

(Pneumatic Clamp → High-Power Pneumatic Clamp)

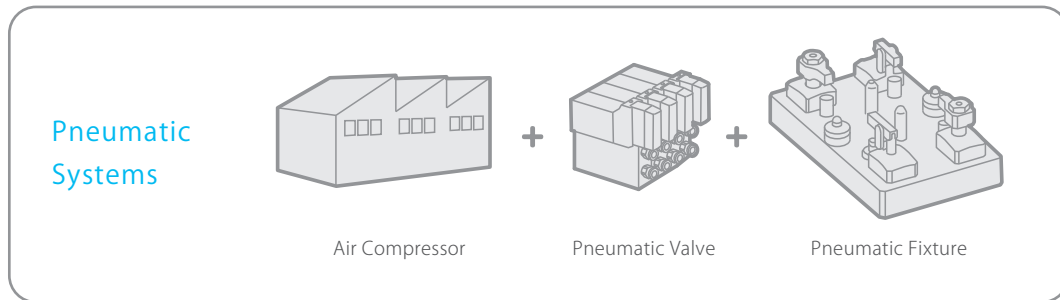

Smaller Footprint

Smaller cylinders, more compact fixtures! High-power pneumatic clamp exerts approximately 3 times higher clamping force than the same size comparison pneumatic cylinder.

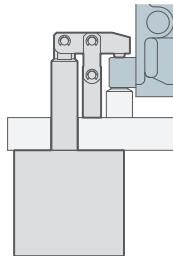

General Pneumatic Cylinder **High-Power Pneumatic Clamp**

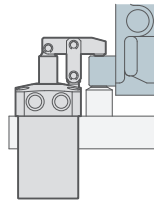

More Compact

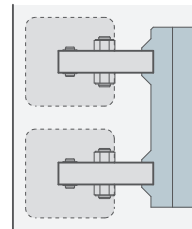

General Pneumatic Cylinder **High-Power Pneumatic Clamp**

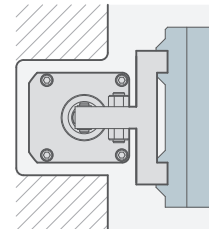

The number of clamps can be reduced

High Speed

Holding force with mechanical locking (wedge) function enables high speed machining on the back face.

Displacement Amount

※ Results of machining by our own.

【 Machining Condition 】

Drill Diameter	8.5 mm	Cutting Speed	25 m/min
Main Axis Revolution	936 rpm	Feed Speed	0.100mm/rev
Workpiece Material	S45C	Clamping Force	860N (430N×2)

High-Power Pneumatic Clamp
(model WHE1000 Cylinder Outer Diameter φ46)

Comparison Pneumatic Clamp
(model WHA0320 Cylinder Outer Diameter φ46)

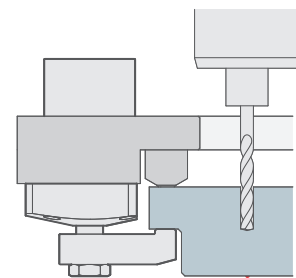
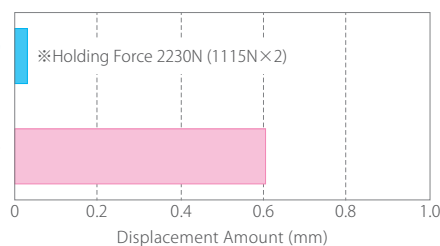

Displacement Amount Measurement Sensor

Pneumatic Systems



Model WHE



Model WCE

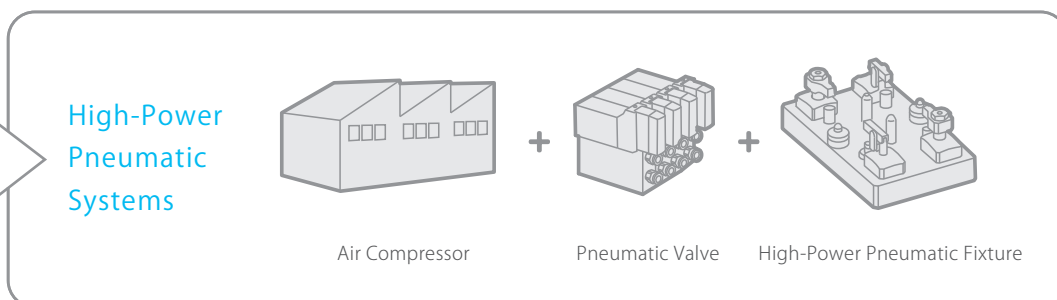

High Quality

Optimum clamping force does not distort workpiece and holding force is strong enough to withstand machining loads.

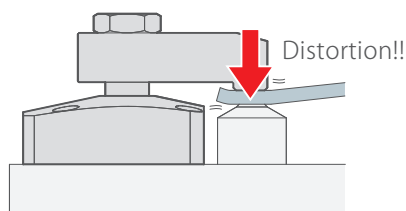

Strong clamping force distorts the workpiece.

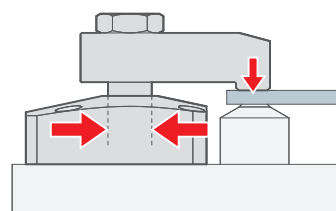

Clamping force is lowered, yet workpiece is supported with holding force.

Light Weight

By reducing the weight of fixture, the load to equipment is minimized such as NC table.

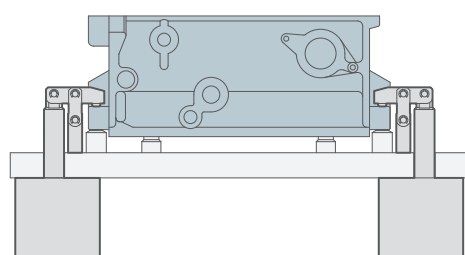

General Pneumatic Cylinder

Fixture Weight 10% reduced

※ Reference when workpiece size is 300×260

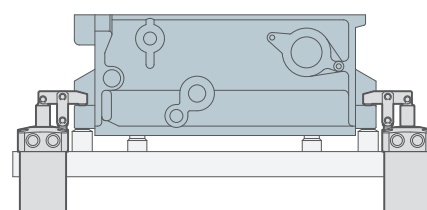

High-Power Pneumatic Clamp

High-Power Pneumatic Series

No Interference • Minimum Setup

Smaller Footprint • Light Weight

By reducing the weight of fixture, the load to equipment is minimized such as NC table.

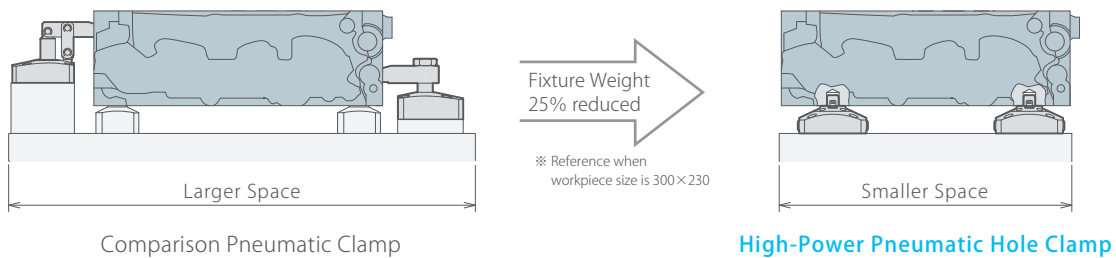

High Power

Equivalent clamping force to hydraulic clamp is achieved by mechanical locking (wedge) function.

Clamping Force at Air Pressure 0.4MPa



Safety Function

The self-lock function with mechanical lock and internal spring will ensure safety even at 0MPa.

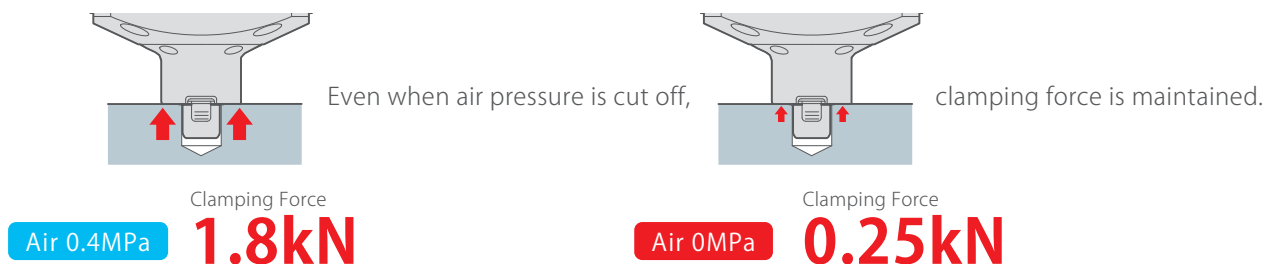

※ Indicates the clamping force of SWE2000.



Model SWE

Hole Clamp

• Smaller Footprint

Transfer

Compact and light weight loading/lifting hand part enables to downsize the transfer equipment.

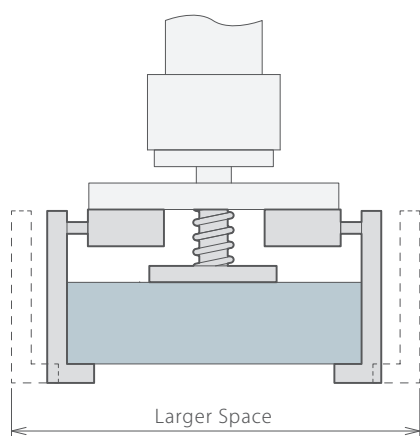

Loading/Lifting Hand with Linear Cylinder

Mass of hand
45% reduced

※ Reference when
workpiece size is 300×230×120

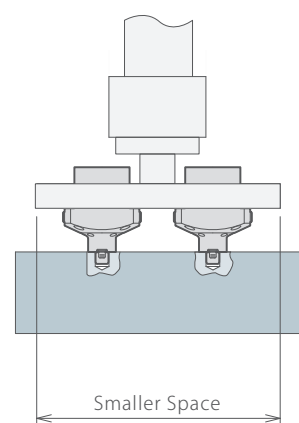

High-Power Pneumatic Hole Clamp

Using SWE with expansion locating pin secures loading/unloading and transfer with a robot.



Model WM/WK

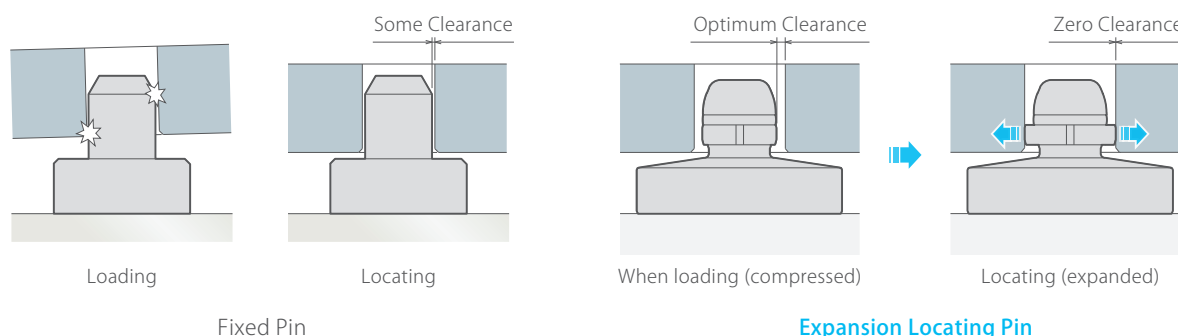

Loading

Locating

When loading (compressed)

Locating (expanded)

Fixed Pin

Expansion Locating Pin

Fixture gets stuck.
Some Clearance

Easy Loading • Zero Clearance
= High Accuracy

High-Power Pneumatic Series

The prevention of chattering and

Chattering Prevention

After the plunger touches the workpiece with slight spring force, it is locked tightly with the wedge function, preventing chattering and deformation of the workpiece.

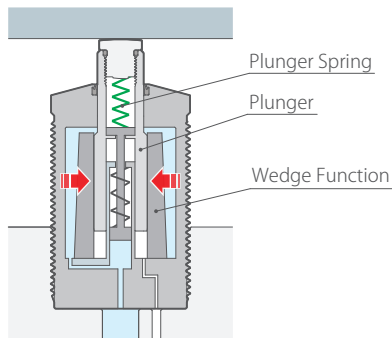

< Internal Action Image >

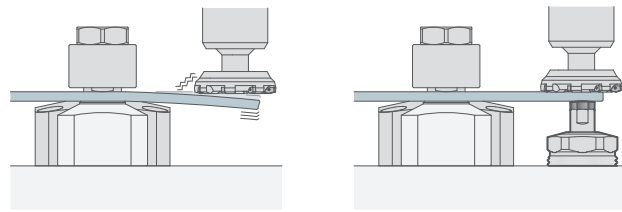

Chattering

No Chattering!!

Deformation Prevention

Plunger is locked where it touches the workpiece within the stroke range.

Without Work Support

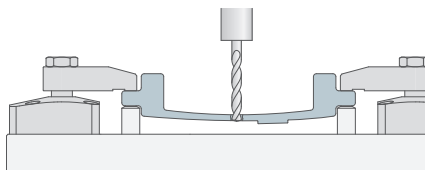
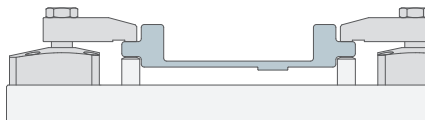

With Work Support

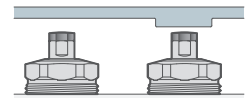
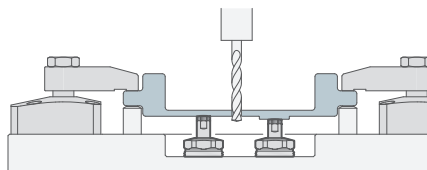
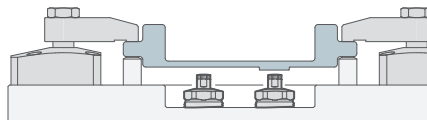

Before plunger is lifted up

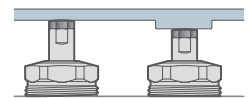

Locked after touching workpiece

Bending

No Bending!!



Model WNC

Work Support deformation improves accuracy.

The World's Smallest Work Support Model

The world's smallest size M22 is added



Supporting force is 2.5 times higher than comparison model.

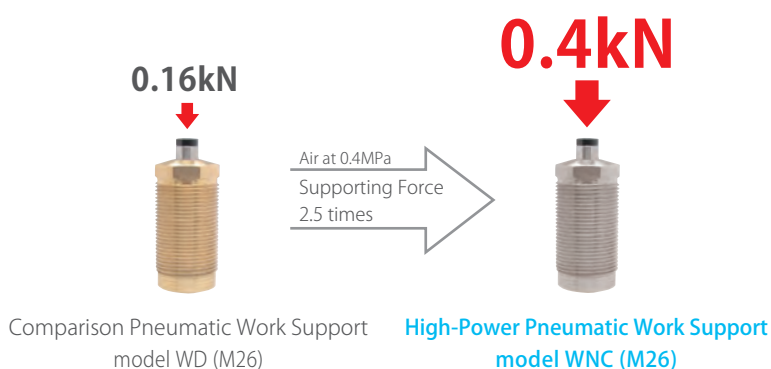

With air sequence valve, it is easy to add a circuit for work support.



Model BWD

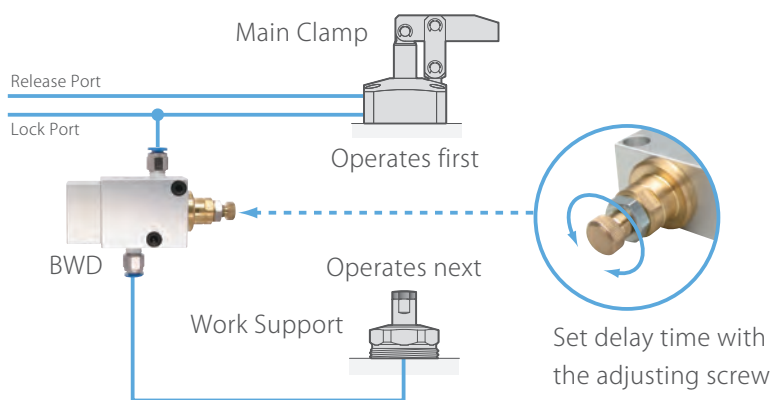

Add the work support circuit by separating clamp circuit.

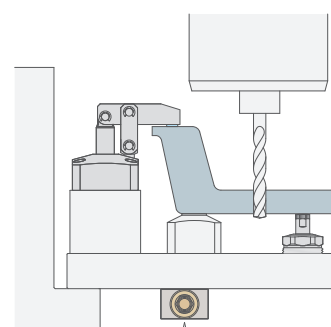

Able to install BWD on the back side of fixture

The Fastest Fixture Setup with Powerfully locks the fixtures,

Work Efficiency

It is very difficult to position 10 kilogram workpiece on fixed pins.
For pallet clamp, anyone can change fixtures with high accuracy.

Fixed Pin + Manual Tightening with Bolt



Difficult to load • Apt to get stuck

High-Power Pneumatic Pallet Clamp

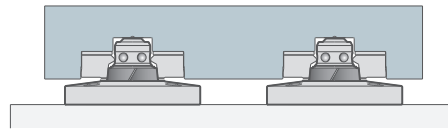

Easy to load

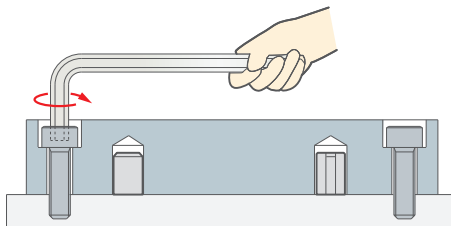
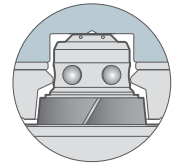

Manual Tightening
Accuracy correction required

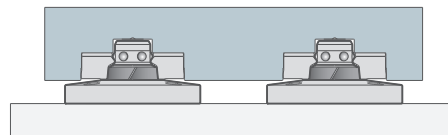

Locking in mere seconds
No accuracy correction required

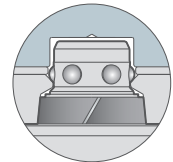

Ensures Accuracy

Locating repeatability is constantly $3 \mu\text{m}$ no matter how many fixtures are set to a table ^{Table Fixture} (1 : n).
The Pallet Clamp can compensate center distance inaccuracies with our unique movable taper sleeve technology.

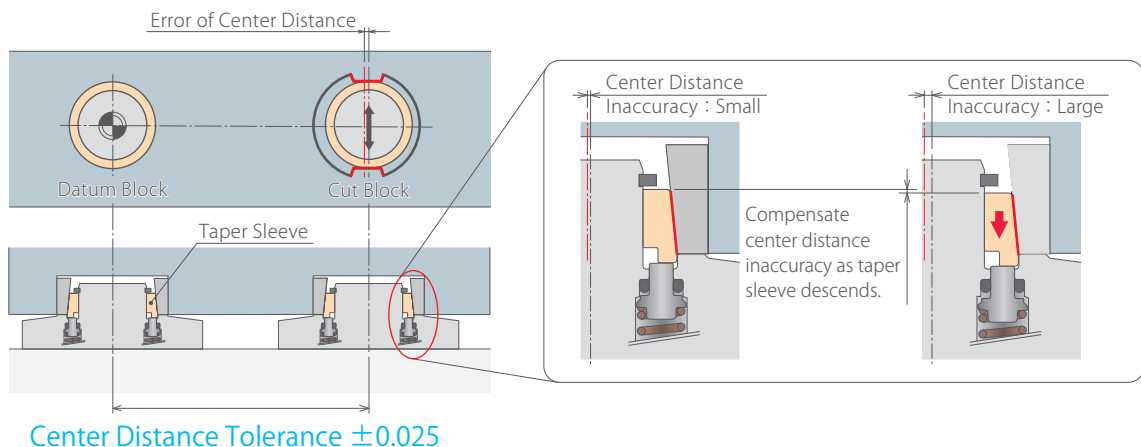



Model WVS

Kosmek Pallet Clamp and locating accuracy is $3\mu\text{m}$

Compact

High-power pneumatic pallet clamp has the same size and equivalent force as hydraulic pallet clamp because of mechanical locking (wedge) function.

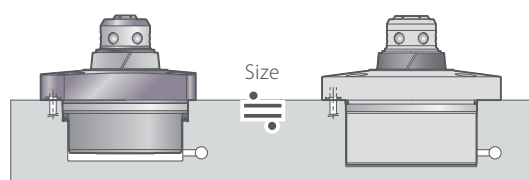

Hydraulic Pallet Clamp
model VS

High-Power Pneumatic Pallet Clamp
model WVS

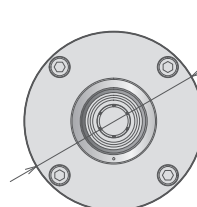

Exterior Diameter : Clamping Force

- $\phi 66$: MAX. 4.0kN
- $\phi 76$: MAX. 6.3kN
- $\phi 94$: MAX. 9.9kN
- $\phi 118.5$: MAX. 15.7kN

※ Clamping force when air pressure is at 0.5MPa.

Screw Locator

Locating within $3\mu\text{m}$ just with bolts



Equivalent to Round Pin
Equivalent to Diamond Pin

Model VXF

Work Efficiency

Taper pin prevents chattering, and anyone can change fixtures with high accuracy.

Ensures Accuracy

Similar to pneumatic pallet clamp, locating repeatability is consistently $3\mu\text{m}$ no matter how many fixtures are set to a table (1 : n).

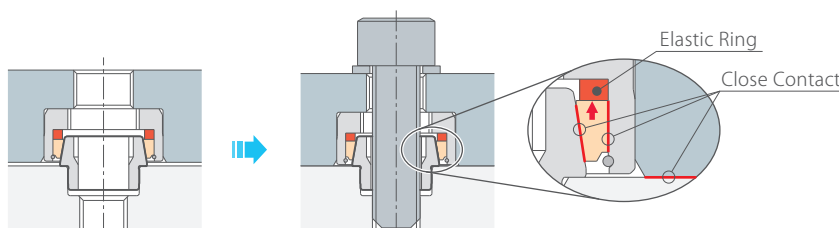

< During Pallet Loading >

< Locating Completed >

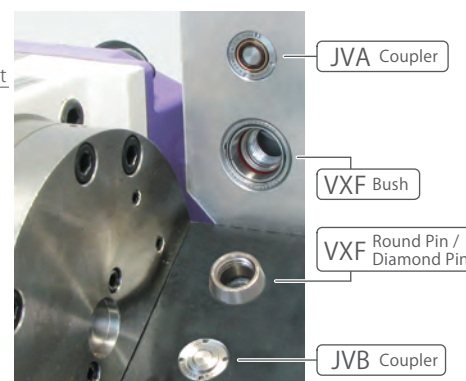

Auto Coupler

JVA/JVB auto coupler can be used with VXF.

Specifications

※ For detailed specifications please refer to our website or catalog.

High-Power Pneumatic Swing Clamp
model **WHE**



Model No.	Exterior Body Diameter	Cylinder Output Force	Operating Pressure Range
WHE0600	φ 40	0.23 ~ 0.57 kN	0.2 ~ 0.5MPa
WHE1000	φ 46	0.39 ~ 0.98 kN	
WHE1600	φ 54	0.63 ~ 1.57 kN	
WHE2500	φ 64	0.98 ~ 2.44 kN	
WHE4000	φ 77	1.54 ~ 3.86 kN	

※ Cylinder output force differs from clamping force/holding force.

High-Power Pneumatic Link Clamp
model **WCE**



Model No.	Exterior Body Diameter	Cylinder Output Force	Operating Pressure Range
WCE0601	φ 40	0.30 ~ 0.62 kN	0.2 ~ 0.5MPa
WCE1001	φ 46	0.49 ~ 1.00 kN	
WCE1601	φ 54	0.79 ~ 1.64 kN	
WCE2501	φ 64	1.24 ~ 2.53 kN	
WCE4001	φ 77	1.98 ~ 4.04 kN	

※ Cylinder output force differs from clamping force/holding force.

High-Power Pneumatic Hole Clamp
model **SWE**



Model No.	Exterior Body Diameter	Clamping Force	Workpiece Hole Diameter	Operating Pressure Range
SWE1000	φ 46	0.7 ~ 1.5 kN	6.0 ^{+0.7} _{-0.3} ~ 9.0 ^{+0.7} _{-0.3}	0.2 ~ 0.5MPa
SWE2000	φ 54	1.0 ~ 2.2 kN	9.0 ^{+0.7} _{-0.3} ~ 13.0 ^{+0.7} _{-0.3}	

※ Workpiece hole diameter should be specified in incremental of every 0.5mm.

※ Workpiece Hardness : Less than HB250

High-Power Pneumatic Work Support
model **WNC**



Model No.	Outer Diameter Thread Size	Supporting Force	Operating Pressure Range
WNC0350	M22×1.5	0.03 ~ 0.59 kN	0.25 ~ 0.7MPa
WNC0600	M26×1.5	0.1 ~ 1.0 kN	
WNC1000	M30×1.5	0.2 ~ 1.7 kN	
WNC1600	M36×1.5	0.3 ~ 2.5 kN	
WNC3000	M45×1.5	0.7 ~ 4.8 kN	
WNC6000	M60×2	1.6 ~ 9.0 kN	

High-Power Pneumatic Pallet Clamp
model **WVS**



Model No.	Exterior Body Diameter	Clamping Force	Locating Repeatability	Operating Pressure Range
WVS0040	φ 45	2.4 ~ 4.0 kN	0.003mm	0.2 ~ 0.5MPa
WVS0060	φ 55	3.9 ~ 6.3 kN		
WVS0100	φ 69	5.8 ~ 9.9 kN		
WVS0160	φ 87.5	9.0 ~ 15.7 kN		

Application Examples for Non-Machining Equipment

High-Power Pneumatic Series is used not only for machining equipment, but also for various production equipment.

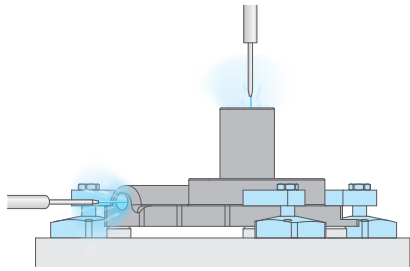

Washers

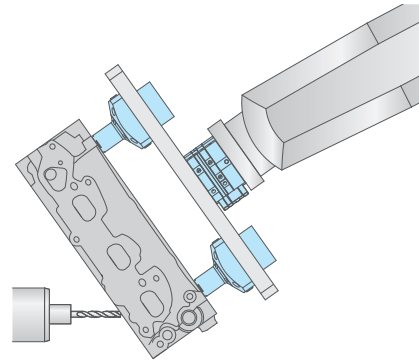

Deburring with Robots

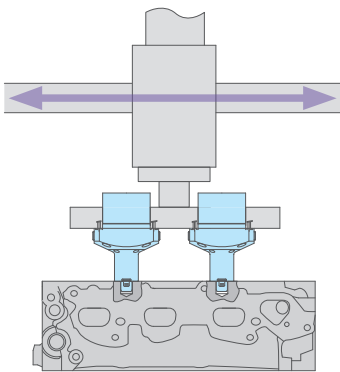

Transfer

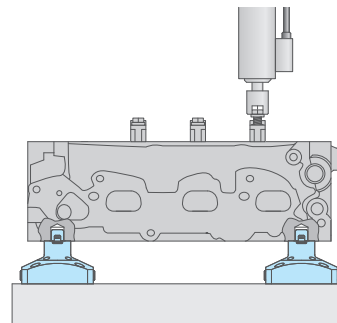

Assembling Equipment

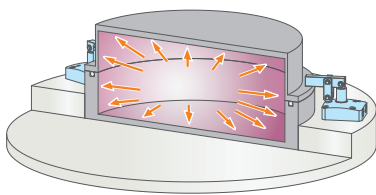

Fixing Pressure Vessel

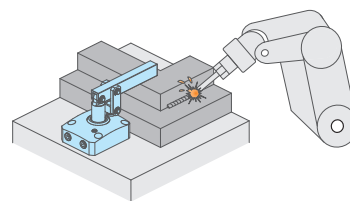

Welding ※ Please contact us when spatter measure is required.

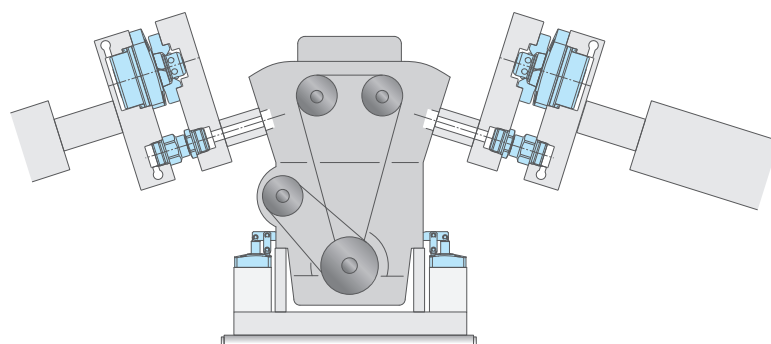

Testing Equipment

KOSMEK

Harmony in Innovation

HEAD OFFICE 1-5, 2-Chome, Murotani, Nishi-ku, Kobe 651-2241
TEL.+81-78-991-5162 FAX.+81-78-991-8787

BRANCH OFFICE (U.S.A.) KOSMEK (U.S.A.) LTD.
1441 Branding Avenue, Suite 110, Downers Grove, IL 60515 USA
TEL.+1-630-241-3465 FAX.+1-630-241-3834

THAILAND REPRESENTATIVE OFFICE 67 Soi 58, RAMA 9 Rd., Suanluang, Suanluang, Bangkok 10250
TEL.+66-2-715-3450 FAX.+66-2-715-3453

- FOR FURTHER INFORMATION ON UNLISTED SPECIFICATIONS AND SIZES, PLEASE CALL US.
- SPECIFICATIONS IN THIS LEAFLET ARE SUBJECT TO CHANGE WITHOUT NOTICE.



JQA-QMA10823
KOSMEK HEAD OFFICE



MS
JAB
CM009

<http://www.kosmek.co.jp>